

THIS DRAWING IS UNPUBLISHED. RELEASED FOR PUBLICATION, 19 .  
 © COPYRIGHT 19 BY AMP INCORPORATED. ALL INTERNATIONAL RIGHTS RESERVED.

LOC	DIST	P	F	ZONE	LTR	DESCRIPTION	DATE	APPD
G	14				D	REVISED PER 0720-0937-96	30MAY96	OKS MJS

**METRIC**  
 DIMENSIONS LISTED IN mm [ INCHES ]

<b>AMP</b> WIRE RANGE	E13288 Listed
22-16 AWG STRANDED	22-16 AWG STRANDED
LR7189 Certified	MILITARY P/N AND CLASS
NOT CERTIFIED	NOT APPLICABLE

△ STAMP AMP 22-18\* APPROX AS SHOWN  
 22-16 TERMINALS ARE STAMPED 22-18 IN  
 ACCORDANCE WITH MILITARY SPECIFICATION  
 MIL-T-7928; COMMERCIAL WIRE RANGE IS 22-16

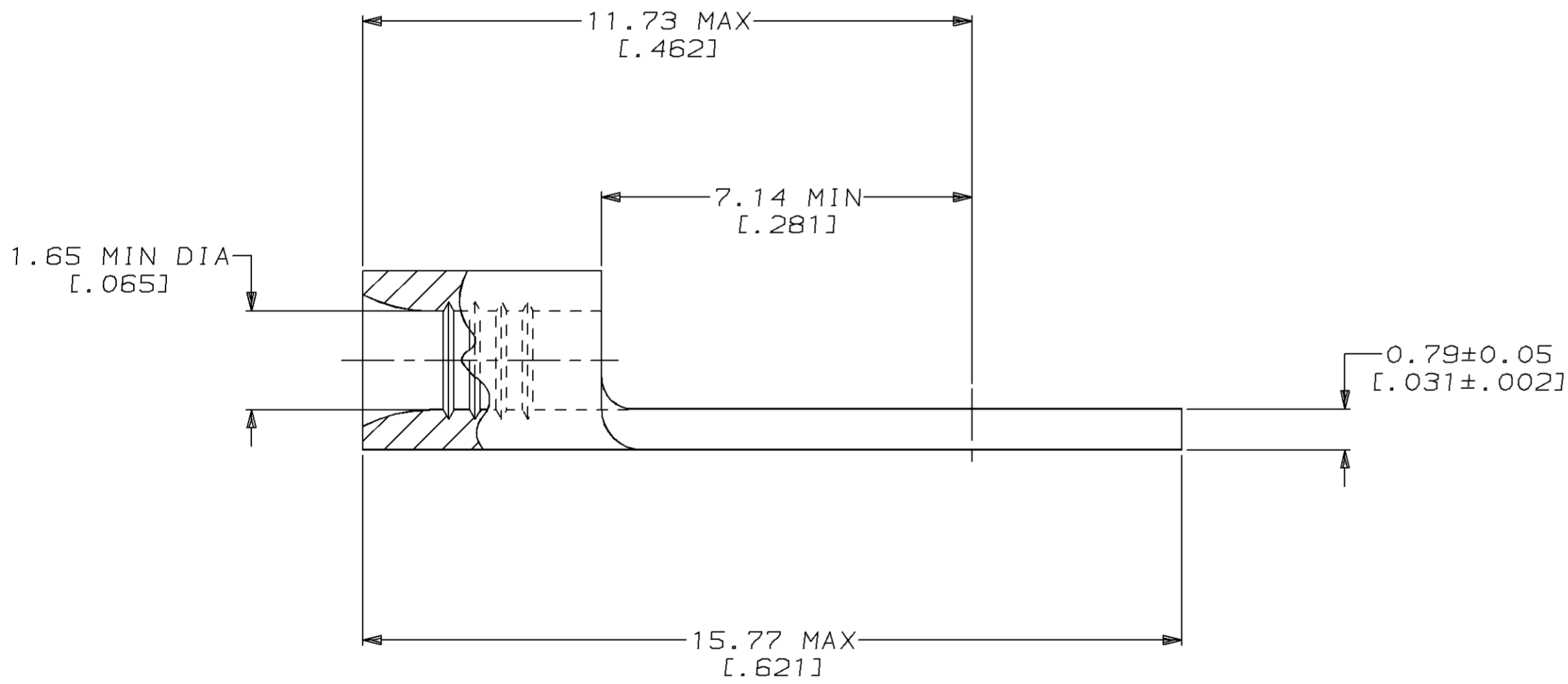
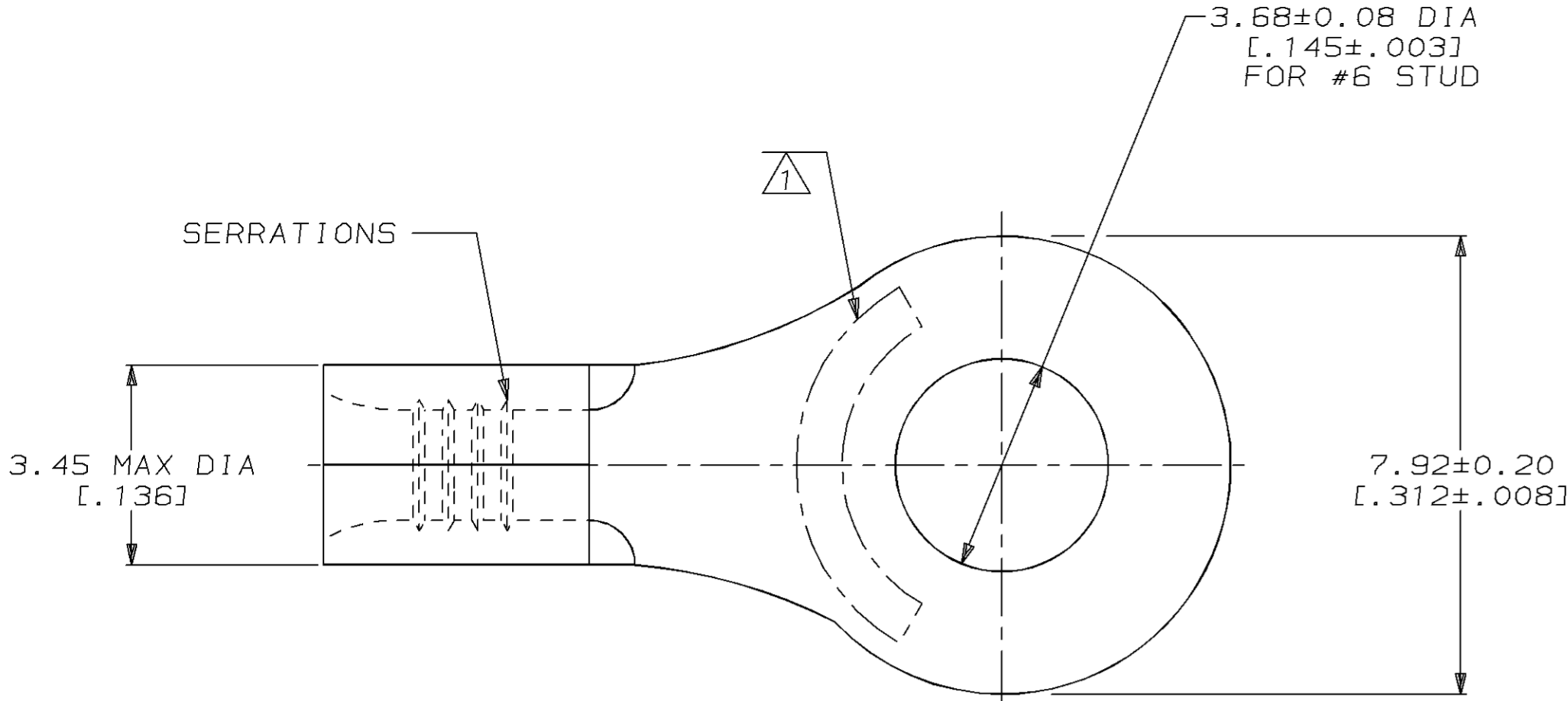

QUANTITY	PACKAGE TYPE	PART NO
50	LOOSE PIECE, BOX	8-30691-2
5000	ON TAPE, REEL	1-30691-1
-	LOOSE PIECE	30691

**AMP INCORPORATED**  
**CUSTOMER SERVICE SYSTEMS**

FOR ADDITIONAL  
 PRODUCT INFORMATION OR  
 COPIES OF DRAWINGS  
 AND TECHNICAL DOCUMENTS

FOR APPLICATION  
 TOOLING INFORMATION

FOR ORDER ENTRY

PRODUCT INFORMATION CENTER  
 1-800-522-6752

TOOLING ASSISTANCE CENTER  
 1-800-722-1111

1-800-526-5142

MAX RECOMMENDED OPERATING  
 TEMPERATURE:  
 170°C MAX

VOLTAGE RATING:  
 NOT APPLICABLE

WIRE CROSS SECTIONAL AREA RANGE:  
 0.26-1.65mm<sup>2</sup> [509-3,260] CIR MILS  
 STRANDED

THIS DRAWING IS A CONTROLLED DOCUMENT FOR  
 AMP INCORPORATED. IT IS SUBJECT TO CHANGE  
 AND THE CONTROLLING ENGINEERING ORGANIZATION  
 SHOULD BE CONTACTED FOR THE LATEST REVISION.

DO NOT SCALE PRINT.  
 UNLESS SPECIFIED  
 DIMENSIONS IN mm [INCHES]  
 TOLERANCES ON:  
 2 PLC DEC ± -  
 3 PLC DEC ± -  
 ANGLES ± -

MATERIAL  
 COPPER PER  
 ASTM B-152  
 ANNEALED

FINISH  
 TIN PLATE  
 0.00254[.000100] MIN  
 THK PER MIL-T-10727

DR 2-3-93  
 TA BRINKMAN

CHK 2-3-93  
 DA PATTERSON

APPD 2-3-93  
 DE MILLER

APPD 2-3-93  
 JL MECKLEY

PRODUCT SPEC  
 -

APPLICATION SPEC  
 -

WEIGHT -

**AMP** AMP Incorporated  
 Harrisburg, PA 17105-3608

NAME  
**TERMINAL, RING TONGUE,  
 BUDGET**

SIZE  
 C 00779

DRAWING NO  
 C-30691

SCALE 10:1

SHEET 1 OF 1